

TOUCH II

User friendly and totally programmable microprocessor with 7" touch screen.
USB Connection. Online platform free of charge for programming, telemetry, data analysis...thanks to the IoT.
Videos show on display: ads, instructions, (useful for coin laundry).
37 languages.

OUTSTANDING FEATURES

Reversing drum action as standard.
Stainless steel drum as standard.
Frequency inverter as standard.

EFFICIENCY

DOUBLE FLOW - mixed axial-radial airflow.
Big fluff filter.

VERSATILITY

Make to order - customisation.
Wet Cleaning.
OPL > Coin laundry - Standard OPL model easily trasformable to coin laundry uses (DTT-11 to DTT-35).

CONNECTIVITY

IoT - **DOMUSCONNECT** standard.
Management of laundries: OPL and self-service.
Remote payment (coin laundry).

ERGONOMICS

Drawer as fluff filter, stainless steel mesh.
Biggest door diameters.
Opening sense of door adjustable on site.

MAINTENANCE

Control panel: easy access.
Technical menu: statistics for technicians.
Easy access to parts for reparability.

OTHERS

Grey skinplate outer casing, stainless steel look.
NEW: Geared motor drive on models DTT-45 to DTT-80
SOFT DRY - new drum with stamped holes.
COOL DOWN - anti-wrinkle at the end of the cycle.
Heating options: electric, gas and steam.
CE approved



OPTIONS

- DOMUS LAUNDRY App - Self service
- License IoT - DOMUSCONNECT
- Natural gas heated tumble dryer
- Reinforced drum for heavy-duty use 28-35kg
- EFFICIENT DRY Humidity sensor
- Double doorglass DTT-28-80
- Fire extinguisher SFEX DTT-35
- Opposite door opening DTT-11-35
- Tropicalized model
- Dosing-spraying
- Back panel with air filter DTT-11 to DTT-35
- Fluff filter with grid 0,6 mm (standard is 0,3 mm)
- Fluff filter with grid 1,2 mm (standard is 0,3 mm)
- Stainless steel front and side panels DTT-35
- Front panel in stainless steel DTT-28/35
- Steam battery in stainless steel DTT-28/35
- Low pressure steam battery DTT-28/35
- Maritime wooden packing DTT-35
- 400V 3N 60 Hz DTT-11-35
- 230V 3~ 50 Hz DTT-22/28/35 E
- 230V 3~ 60 Hz DTT-22/28/35 E
- 230V 3~ 60 Hz DTT-11-35 G/S
- 440/480V 3~ 60 Hz DTT-22/28/35 (marine)
- Several payment systems for self-service

CAPACITY & DRUM	UNIT.	DTT-35
Capacity 1/18	Kg	36,7
	lb	80,8
Capacity 1/20	Kg	33
	lb	72,8
Ø Drum	mm	947
	inch	37,28
Drum length	mm	936
	inch	36,85
Drum volume	l	660
	cu ft	23,30
Ø Door hole	mm	802
	inch	31,57
Door center height	mm	1.040
	inch	40,94
Height from floor to bottom of door	mm	578
	inch	22,74
ELECTRIC HEATING		
Evaporation capacity	L/h	31,1
	US gallon/h	8,22
Hourly output	Kg/h	60
	lb/h	132,3
Installed heating power	kW	36
Installed electrical power	kW	37,15
GAS HEATING		
Evaporation capacity (gas model)	L/h	32,1
	US gallon/h	8,480
Hourly output (gas model)	Kg/h	63,9
	lb/h	140,9
Installed gas heating power	kcal/h	35254
	Btu/h	139899
Installed gas heating power	kW	41
Installed electrical power	kW	1,15
Instant propane gas consumption (G31)	Kg/h	3,51
	lb/h	7,74
Instant natural gas consumption (G20)	m ³ /h	4,34
	cfm	2,55
Ø Gas inlet	BSPP ISO 228-1	1/2"
STEAM HEATING		
Installed steam heating power	kW	50,10
	Btu/h	170948
Installed electrical power	kW	1,15
Steam consumption (8 barG) - Standard	kg/h	89
Steam consumption (116 psiG)	lb/h	107,2
Steam pressure	barG	6 - 9
	psiG	87 - 130,5
Standard steam inlet - outlet	BSPT- ISO7.1	1"
Standard steam inlet - outlet	NPT ANSI B1.20.1 Tapered	1"
Steam consumption (5 barG) - Low Pressure	kg/h	93
Steam consumption (72,5 psiG) - Low Pressure	lb/h	112
Steam pressure (low pressure)	barG	3 - 6
	psiG	43,5 - 97
Low pressure steam inlet - outlet	BSPT- ISO7.1	1" 1/2
THERMAL OIL HEATING		
Installed heating power	kW	-
Installed electrical power	kW	-
Fluid consumption (T max 175°C)	m ³ /h	-
Thermal oil connection	BSP	-

POWER AND VENTILATION				
Drum motor power		kW	0,55	
Fan motor power		kW	0,55	
Nominal air flow rate		m ³ /h	1.200	
		cfm	706	
Ø Fume exhaust		mm	200	
		inch	7,87	
HEAT EMISSION				
Maximum total heat emission		kW	3,6	
		Btu/h	12291	
Max. front heat emission		kW	2,5	
		Btu/h	8604	
CONNECTIONS				
Tension 230V - I + N + T		Nº x mm ² / A	E	G / S
Tension 230V - III + T		Nº x mm ² / A	4 x 50 / 125A	3 x 1,5 / 16A
Tension 400V - III + N + T		Nº x mm ² / A	5 x 16 / 63A	3 x 1,5 / 16A
NET DIMENSIONS / D. WITH PACKING				
Net / gross width		mm	985 / 1.065	
		inch	38,8 / 41,9	
Net / gross depth		mm	1.210 / 1.310	
		inch	47,6 / 51,6	
Net height / gross height (without heating*)		mm	1.975 / 2.080	
		inch	77,8 / 81,9	
Net / gross weight		Kg	260 / 285	
		lb	573 / 628	
OTHERS				
Sound level		dB	65	

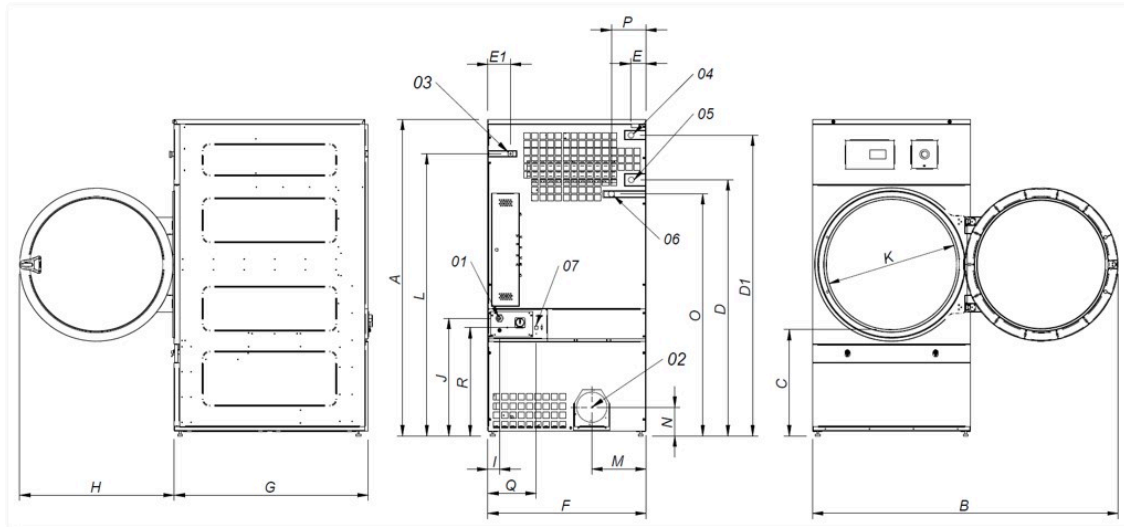

- 01 Power supply
- 02 Fumes output Ø 200
- 03 Gas inlet 1/2"
- 04 Steam inlet 1"
- 05 Condensate 1"
- 06 Sprinkler valve 3/4"
- 07 Ethernet connection (only TOUCH Control)

	A	B	C	D	D1	E	E1	F	G	H	I	J	K	L	M	N	O	P	Q	R
DTT-28	1.975	1.910	660	1.590	1.875	102	130	985	1.054	970	70	730	802	1.760	337	178	1.510	215	301	676
DTT-35	1.975	1.910	660	1.590	1.875	102	130	985	1.210	970	70	730	802	1.760	337	178	1.510	215	301	676