

TOUCH II

User friendly and totally programmable 4,3" microprocessor. USB Connection. Online platform free of charge for programming, telemetry, data analysis...thanks to the IoT. Videos show on display: ads, instructions, (useful for coin laundry). 37 languages.

VERSATILITY

OPL <> COIN - Standard models can be programmed as OPL or coin laundry version, central pay, etc.
SINGLE <> STACKED - Models can be stacked on top of a washer or on another dryer.
Control panels can be assembled between both drums for better ergonomics.
Ideal for multiple solutions: hotels, hostels, campings, coin laundries, facility services (mops), gyms, etc.
Wet Cleaning features.

OUTSTANDING FEATURES

Reduced drying times (less than 45 minutes).

CONNECTIVITY

IoT - **DOMUSCONNECT** standard.
Management of laundries: OPL and COIN.
Remote payment.

EFFICIENCY

Optimised airflow.
Axial airflow.
Wide fluff filter as drawer.
Efficient design.

ROBUSTNESS

Outer casing in grey skinplate (white lacquered in HPDL model).
Robust aluminium door.
Industrial fan and powerful airflow.
Sturdy construction of the dryer structure and panels.

OTHERS

Galvanized drum.
Electric and gas heated models.
Grey skinplate panels.
CE approved product



OPTIONS

- DOMUS LAUNDRY App - Self service
- Fire suppression system SFEX (only TOUCH II models)
- License IoT - DOMUSCONNECT
- Natural gas heated tumble dryer
- Plinth for better ergonomics in skinplate for HPD (except HPDL)
- Plinth for better ergonomics in stainless steel for HPD (except HPDL)
- Drum stainless steel AISI 304
- Outer casing stainless steel AISI 430
- Reverse door opening
- Control panel mounted below
- Tropicalized model (TOUCH II)
- EFFICIENT DRY humidity control (only TOUCH II models)
- Several payment systems for self-service
- 400V 3 / 230 I / 3 60 Hz No HPI
- 440-480V 3~ 60 Hz (marine)

CAPACITY & DRUM		UNIT.	HPD-10 TOUCH II	
Capacity 1/18		Kg	11,1	
		lb	24,5	
Capacity 1/20		Kg	10	
		lb	22	
Ø Drum		mm	590	
		inch	23,2	
Drum length		mm	690	
		inch	27,2	
Drum volume		l	200	
		cu ft	7,06	
Ø Door hole		mm	480	
		inch	18,9	
Door center height		mm	554	
		inch	21,8	
Height from floor to bottom of door		mm	250	
		inch	9,84	
ELECTRIC HEATING				
Evaporation capacity		L/h	6,35	
		US gallon/h	1,68	
Hourly output		Kg/h	12,5	
		lb/h	27,56	
Installed heating power		kW	4,5 / 6,75	
Installed electrical power		kW	4,92 / 7,17	
GAS HEATING				
Evaporation capacity (gas model)		L/h	6,35	
		US gallon/h	1,68	
Hourly output (gas model)		Kg/h	12,5	
		lb/h	27,56	
Installed gas heating power		kcal/h	5761	
		Btu/h	22861,3	
Installed gas heating power		kW	6,70	
Installed electrical power		kW	0,42	
Instant propane gas consumption (G31)		Kg/h	0,57	
		lb/h	1,26	
Instant natural gas consumption (G20)		m ³ /h	0,71	
		cfm	0,42	
Ø Gas inlet		BSPP ISO 228-1	1/2"	
POWER AND VENTILATION				
Drum motor power		kW	0,37 (2)	
Fan motor power		kW	0,37(2)	
Nominal air flow rate		m ³ /h	300	
		cfm	177	
Ø Fume exhaust		mm	100	
		inch	3,94	
HEAT EMISSION				
Maximum total heat emission		kW	0,5	
		Btu/h	1536	
Max. front heat emission		kW	0,3	
		Btu/h	1075	
CONNECTIONS				
Tension 230V - I + N + T		Nº x mm ² / A	E 3 x 10 / 40A	G 3 x 1,5 / 10A
Tension 230V - III + T		Nº x mm ² / A	4 x 4 / 25A	3 x 1,5 / 10A (3)
Tension 400V - III + N + T		Nº x mm ² / A	5 x 2,5 / 16A	3 x 1,5 / 10A (4)
NET DIMENSIONS / D. WITH PACKING				
Net / gross width		mm	680 / 710	
		inch	26,8 / 28	

Net / gross depth	mm	775 / 832
	inch	30,5 / 32,8
Net / gross height	mm	1.056 / 1.141
	inch	41,6 / 44,9
Net / gross weight	Kg	93 / 111
	lb	204 / 245
OTHERS		
Sound level	dB	62

- (1) Configurable via a terminal block system.
- (2) It's a single motor for both the drum and fan.
- (3) Connect two phases and ground.
- (4) Connect phase, neutral, and ground.

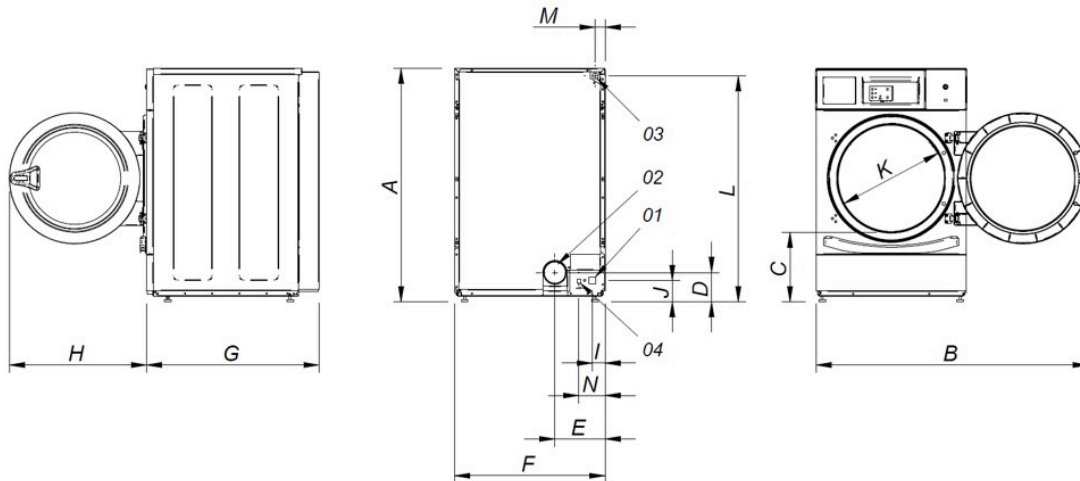

- 01 Power supply
- 02 Fumes output Ø 100
- 03 Gas inlet 1/2"
- 04 Ethernet connection (only TOUCH control)

	A	B	C	D	E	F	G	H	I	J	K	L	M	N
HPD-8	1.056	1.227	320	140	226	680	722	615	57	91	480	1.015	50	118
HPD-10	1.056	1.227	320	140	226	680	775	615	57	91	480	1.015	50	118